

Glue Laminated Bamboo (GluBam) for Structural Applications

Y. Xiao^{1,2,*}, B. Shan¹, R.Z. Yang¹, Z. Li¹, and J. Chen³

¹ Key Laboratory of Building Safety and Energy Efficiency of China Ministry of Education, Hunan University, Changsha 410082, China

² Department of Civil and Environmental Engineering, University of South California, Los Angeles CA 90089, USA

³ Advanced Bamboo and Timber Technologies, Ltd. Changsha, China
yanxiao@hnu.edu.cn, yanxiao@usc.edu

Abstract. In today's trend of sustainable development, there is a renewed interest to use bamboo for modern building and bridge structures. However, traditional use of raw bamboo culms is not the only and nor the most effective application. The authors developed a laminated bamboo or glubam for general structural applications. This paper describes the manufacturing process of glubam, investigates and analyzes its energy consumption and carbon dioxide emission, and provides main mechanical properties through material testing. Analysis results and comparison with other comparable construction materials show the eco-friendly performance of glubam. The mechanical properties of glubam are promising for general use in construction. Research on connections using steel bolts shows the good connectivity of glubam components similar to timber structures. The paper also summarizes the authors' extensive experimental tests on various glubam components, such as full-scale girders under static and fatigue loads, wall panels under monotonic and cyclic loads, full-scale room models under simulated earthquake load and fire, etc. Several recent practical design and construction of residential and industrial buildings are also briefly introduced.

Keywords: glubam, production, energy consumption, carbon dioxide emission, mechanical properties, components, design and construction.

1 Introduction

Bamboo has been indispensable in human life and its history being used as building and bridge structural materials can be traced back as long time as wood. Its natural properties are quite comparable to those of wood. However, the original geometrical shape of bamboo culms makes it difficult to be used in modern

* Corresponding author.

construction. Based on abundant material and existing production technology in China, a new type of laminated bamboo that can be used as structural elements are invented by the authors with a trademark of GluBam [1-2].

This paper presents a summary of the authors' recent work on research and development of glue laminated bamboo or glulam for general usage in building and bridge structures.

2 Production of Glulam

The production of Glulam has about five steps consisting of raw bamboo selection; splitting bamboo strips; netting bamboo curtains or mats; gluing and hot-pressing; and post-processing, as shown in Fig.1. The process of producing glulam sheets is similar to that for plywood production [3]. The typical glulam sheets are 30 mm



(a) Glulam sheets



(b) Post-process of structural components

Fig. 1 Production of Glulam

(+/- 2mm), 1220 mm wide and 2440 mm long. These laminated bamboo sheets after cutting, gluing, stacking and compressing, finger-jointing can finally form different structural elements. Figure 1(b) exhibits the production of some glubam columns with a length of 6 m. Detailed discussions about the glubam production can be found in [4].

3 Mechanical Properties and Environmental Impact of Glubam

3.1 Mechanical Properties

The typical glubam structural components use the sheets with bamboo strips arranged with 80% in the longitudinal direction and 20% in the transverse direction, referred to as 4:1 sheet. There are usually 15 or less layers of bamboo curtains, and each is with about 2 mm thickness.

Due to the fact that glubam is a new invention and no testing standard has been established, the standard for timber structure is referenced in the study of mechanical properties of glubam. In Chinese timber structure design standard, design values of mechanical properties of timber are from small clear specimen tests. Being short of timber material, not much plywood is used in China as structural material except some thin wood boards for decoration. In view of the condition of material production and design method, it is reasonable to use small clear specimen test method to obtain mechanical properties for glubam. A large number of specimens were tested and the results are summarized in Table 1.

Table 1 Main mechanical properties of Glubam

Materials	In-plane tensile strength (MPa)	Elastic modulus E_y (MPa)	Elastic modulus E_x (MPa)	G_{xy} (MPa)	G_{yx} (MPa)	In-plane compressive strength (MPa)	Bending strength (MPa)	Density (kg/m ³)
Glubam	82	10400	2600	4.6	7.2	51	99	800~900

3.2 Environmental Impact

The influence on environment of certain material is a quite important aspect in today’s trend towards a sustainable construction industry. It is well known that timber has less carbon and environmental impacts than other industrialized materials including concrete, steel, aluminum, etc. The main reason of timber being “greener” owes to its less processing energy consumption and more carbon dioxide storage [4]. An investigation on environmental impact of glubam was conducted at the authors’ production base located in Yanling County of Hunan Province, where moso bamboo abounds.

3.2.1 General Energy Consumption

According to the mill's actual production condition, some data were gathered to calculate the energy consumption of per cubic meter of glubam sheets. Energy consumptions of glubam production are found from transportation of raw materials, electricity usage, phenol formaldehyde resin, hydraulic oil used in hot compressing machine, heating and cooling water, and fuel in boiler, etc. The energy consumption nested in the production equipment and the factory facilities is also counted. As the result, the energy total consumption of glubam sheets is estimated at $2.67\text{GJ}/\text{m}^3$.

A comparison is made in Fig.2 to show the energy consumptions of glubam and other construction materials including timber, plywood, cement, aluminum and structural steel. Data for cement are from Hammond and Jones [5], the others including timber, plywood, aluminum and structural steel are from Buchanan and Honey [6]. As shown in Fig.2, aluminum and steel are big consumers of energy. Glubam consumes lower energy amount than cement by about 75%, however higher than timber.

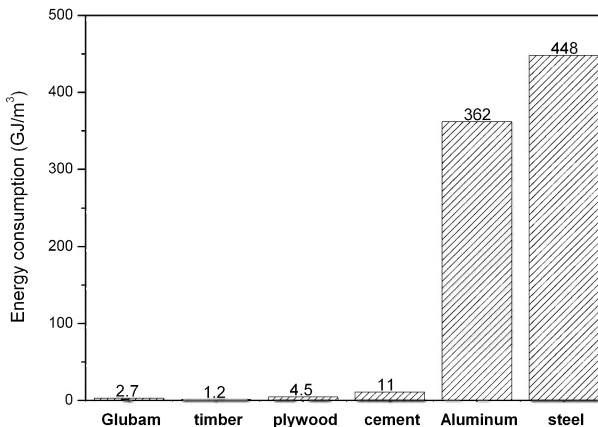

Fig. 2 Production energy consumption of glubam and other conventional materials

3.2.2 Carbon Emission

Low carbon emission of bamboo products has been widely recognized, making it very attractive in today's move towards a sustainable society. Research shows that the carbon dioxide stored in the raw bamboo used in 1m^3 glubam is calculated as 2.166t. Different factors including transportation, electricity, lubricating oil, phenol formaldehyde resin, carbon emission per capita, production equipment (including post process) and plant inventories that contributing to the carbon emission during the manufacturing process of glubam are considered in the calculation. Based on related coefficients, carbon dioxide emission of glubam sheets is calculated as $-261\text{kg}/\text{m}^3$. Apparently, glubam is a carbon negative material.

Histogram shown in Fig.3 compares Glubam with other construction materials including timber, plywood, cement, aluminum and steel in carbon emission. Data for cement are from reference [5], the others including timber, plywood, Aluminum and structural steel are from reference [6]. Cement, Aluminum and steel discharge much more carbon dioxide than the other materials. In comparison, glubam is carbon emission negative, and outperforms timber and plywood.

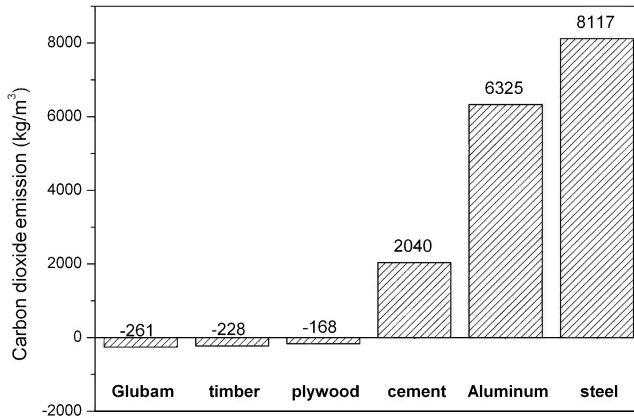

Fig. 3 Carbon dioxide emission of Glubam and other conventional materials

4 Experimental Studies on Bolted Connections of Glubam

4.1 Specimens

In this paper, glubam bolted connection with different end distance and side distance are considered. One end of the specimen is holding end and the other is for testing, as shown in Fig. 4. The bolt diameter is $d=12\text{mm}$ and the hole diameter is $D=14\text{mm}$. The end distance “e” and edge distance “b/2” of the tested end is designed.

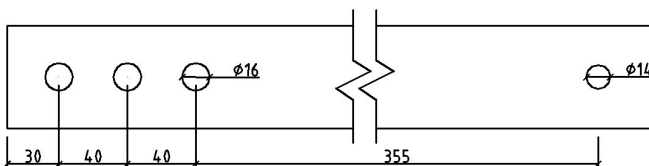

Fig. 4 Dimension of specimens

The experiment involved two major groups of specimens, in each of which there were nine groups of specimens with different end distances and edge distances. Table 2 shows the groups of specimens, where b is the width of glulam board; e is end distance; and d is diameter of bolt hole. The thickness of all glulam specimens is measured at 28mm. There are nine types of specimen configurations, and each has ten specimens both in longitudinal and transverse directions. There were 90 specimens in total in this testing program. Before testing, moisture content (MC) of the specimens was measured by handheld wood moisture meter and the average MC was about 10.0%.

Table 2 Dimension of specimens

V1/H1 groups		V2/H2 groups		V3/H3 groups	
	$e=2d$		$e=2d$		$e=2d$
$b=4d$	$e=3d$	$b=6d$	$e=3d$	$b=8d$	$e=3d$
	$e=4d$		$e=4d$		$e=4d$

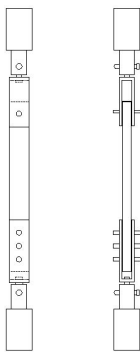

Fig. 5 Fixture of specimen



Fig. 6 Test system

4.2 Test Setup

Testing procedures outlined in ASTM D 5652–95 (R2000) were followed. Figure 5 shows the fixture designed specifically for specimens. In Fig. 6, test system is shown. Universal testing machine is used to control and apply force, as well as to record data. Each specimen was subjected to a displacement-control loading with a rate of 3mm/min until the end of the test, to make sure specimens reach maximum load in not less than 5min and no more than 20min (ASTM 2000).

4.3 Failure Modes

Most design standards use the Johansen’s Yield Model. It is a mechanics-based model to determine the resistance of bolt for various ductile failure modes. In Johansen Yield Theory, it is hypothesized that wood or composite wood and bolt will reach total ductility under dowel bearing stress and moment of bolt, as shown in Fig. 7. This type of failure mode has been considered as the best condition, on which the bolt, side board and middle board will arrive failure at the same time, so all the material energy can be used.

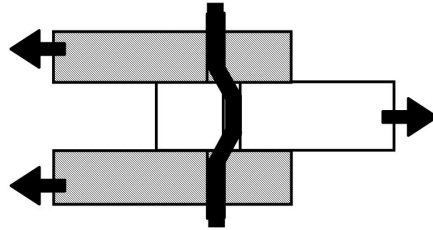

Fig. 7 Ideal failure mode in Johansen Yield Theory

In the tests, there are two main types of failure modes, shearing out and net tension, as shown in Fig. 8 and Fig. 9. Shearing out occurred usually in V group and net tension usually in H group. For single bolted joint, the predominant failure modes include bearing, shearing out, cleavage and net tension. The governing mode and failure load of a joint depend on factors such as orientation of fibers in the members, the joint geometry, and clamping force [7-8]. For bearing strength, it is the ideal failure mode in Johansen Yield Theory and is most desirable. But for specimens in the test, they were clamped by the same prefabricated fixture and no tension was applied on the bolt, so the specimens tended to fail by glubam fracture.



Fig. 8 Failure mode of V group-shearing out

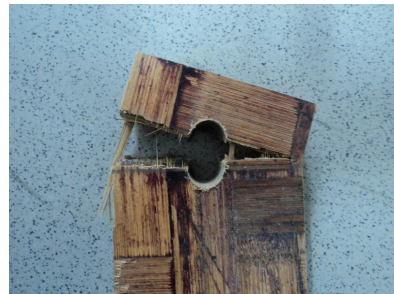

Fig. 9 Failure mode of H group-net tension

4.4 Analysis

The results of the tests show great consistency that was expected, while some phenomenon was unexpected. As shown in Fig. 10, the ultimate strength increases with the increase of side distance. And the same tendency can be found in H group results. However, within V1, V2 and V3 group, relationship between the ultimate strength and the increase of edge distance does not show any regularity, neither does in H group.

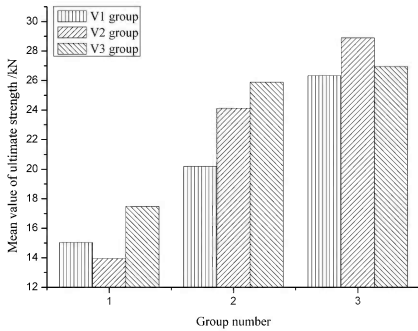

Fig. 10 Ultimate strength V group specimens

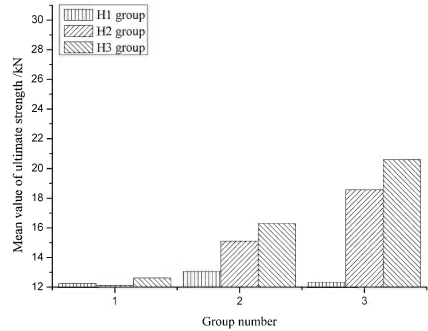

Fig. 11 Ultimate strength H group specimens

Comparing Fig. 10 and Fig. 11, it can be found that V group has correspondingly high strength than H group, which means loading parallel to fiber is beneficial to the ultimate strength of specimen.

In Fig. 11, another phenomenon should be noted that although edge distance is the first factor to influence the ultimate load, the end distance do obviously affect the results especially for H2 and H3 groups. This may be explained from stress distribution around the bolt hole. Many researchers studied the stress distribution both numerically and experimentally. Echavarría and Salenikovich (1998) published a paper about model for predicting brittle failures of bolted timber joints. Their research shows that the stress magnitude around the pin hole decreases with the increase of end distance, which means the large end distance benefits the bearing strength of joints[9].

In ASTM D 5652-95 (Re-approved 2000), the connection yield load is determined by fitting a straight line to the initial linear portion of the load-deformation curve, offset this line by a deformation equal to 5 % of the bolt diameter, and select the load at which the offset line intersects the load-deformation curve. In those cases where the offset line does not intersect the load deformation curve, the maximum load shall be used as the yield load. The initial stiffness is also obtained from the method.

Table 3 summaries the test results. All the failures happened in main glubam board. And according to the two types of failure modes in specimens, equation (1) and (2) are obtained to count the failure strength of single bolt glubam joint.

$$F = 2eSt \tag{1}$$

$$F = (2b - d)Tt \tag{2}$$

And the ultimate strength of specimens can be obtained from equation (3),

$$F = \min(2eSt\alpha, (2b - d)Tt\beta) \tag{3}$$

In which, F is ultimate load, b is side distance, S is the shear strength of Glubam, T is the tension strength, t is the thickness of Glubam board, valued as 28mm, and α , β is the coefficient obtained from regression analysis. Based on the equation, predicted Maximum load is shown in Table 3.

Table 3 Experimental and Analytical Results

Specimen	Yield strength [kN]	Maximum load [kN]	Predicted Max load [kN]	Theoretical ultimate strength	Initial stiffness [kN/mm]	Failure mode*	
V1	V1-1	13.5	15.0	15.6	9.9	5.2	SO
	V1-2	21.0	20.2	23.3	14.8	5.0	SO
	V1-3	23.8	26.3	31.1	19.8	6.1	SO
V2	V2-1	12.0	13.9	15.6	9.9	5.4	SO
	V2-2	22.8	24.1	23.3	14.8	6.4	SO
	V2-3	26.5	28.9	31.1	19.8	6.0	SO
V3	V3-1	16.3	17.5	15.6	9.9	6.0	SO
	V3-2	25.1	25.9	23.3	14.8	7.1	SO
	V3-3	23.2	26.9	31.1	19.8	6.2	SO
H1	H1-1	10.6	12.3	8.62	16.2	3.7	NT
	H1-2	11.6	13.1	8.62	16.2	4.1	NT
	H1-3	10.8	12.3	8.62	16.2	3.8	NT
H2	H2-1	11.1	12.1	14.7	27.6	4.3	NT
	H2-2	14.3	15.1	14.7	27.6	4.4	NT
	H2-3	17.8	18.6	14.7	27.6	4.2	NT
H3	H3-1	11.8	12.6	20.8	39.0	4.2	NT
	H3-2	14.5	16.3	20.8	39.0	4.4	NT
	H3-3	17.5	20.6	20.8	39.0	4.5	NT

Note: SO means shearing out, NT means net tension.

5 Other Studies and Applications of Glubam

5.1 *Static and Fatigue Tests of Full-Scale Girders*

Static test of glubam girders (Fig.12) show their excellent bearing capacity [1]. The use of FRP to reinforce the soffit of the girders can further enhance the load carrying capacity of glubam girders.



Fig. 12 Fatigue test of full-scale glubam girder

The fatigue experiment reduces the bearing capacity of glubam girders approximately by 10% due to the development of weaknesses in finger-joint and gluing face. When the upper value of cyclic load does not surpass its design value, there was no distinct reduction on the stiffness of specimens compared with the static tests. It is clear that excellent flexibility of bamboo contributes to the fine stability of glubam beams in aspect of dynamic response during the fatigue loading.

5.2 *Wall Panel under Monotonic and Cyclic Loads*

Significant numbers of experimental tests were conducted to study the lateral loading behavior of shear wall panels made with glubam sheets and glubam or wood frame studs. Tests show that the light-weight wood shear walls with glubam sheathing panel (as shown in Fig. 13) have good seismic performance as well as the ability to meet the design requirements specified in most timber structure codes. Besides, the processing of this type of shear wall could satisfy the requirements and preconditions of industrial production, as well as easy installation.

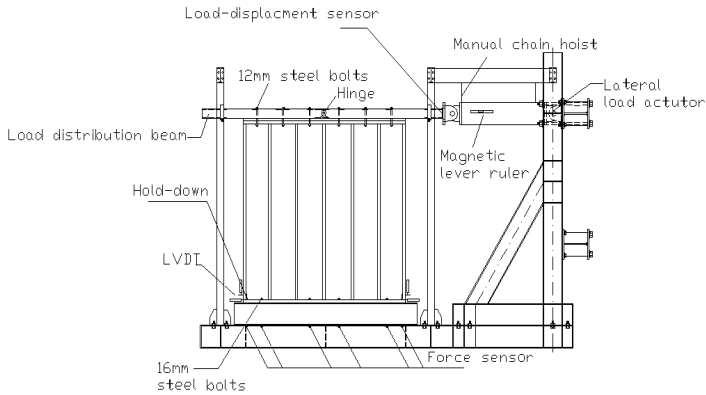

Fig. 13 Test shear wall details

5.3 Full-Scale Room Models under Simulated Earthquake Load and Fire

A full-scale lightweight frame glubam room model was tested on shaking table, with peak input acceleration up to 0.5g. The result shows excellent seismic resistance. Only some minor damage, such as pulling out or penetrating of nails from or through sheathing board (see Fig.14), were observed when seismic acceleration was 0.5g.

The full-scale room model used in the shake-table test was reconstructed with finishing of the inside surfaces by gypsum boards and voids filled with rock wools. A wood crib set at the center of the room was then ignited and allowed to burn for an hour to test the integrity of the lightweight frame glubam building [11]. After one hour of exposure to fire inside the room, the structures of the walls and the ceilings were essentially intact. Like timber structures, the existence of carburization layer under fire can delay further penetrating of fire into the structure.

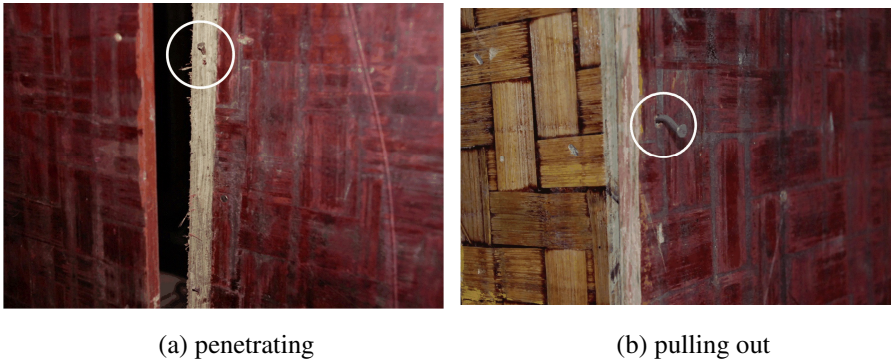

Fig. 14 Damage detail of full-scale glubam room under seismic load

6 Applications of Glubam Structures

The authors also made efforts to build modern bamboo buildings and bridges using the newly developed laminated bamboo structural material, glubam. The structural design is essentially based on the timber design standards and detailing using the material property data obtained from this study. So far the authors have designed and built more than 20 buildings with total building area exceeding 4,000 sq.m. The practice can be categorized into three categories: modular temporary and permanent buildings (Fig. 15(a)); single or multi-story residential buildings (Fig. 15(b)); and heavy space frame buildings (Fig. 15(c)). The temporary glubam buildings were successfully deployed to the area devastated by the May 12, 2008 Sichuan earthquake. In the heavy space frame building as shown in Fig. 15(c), the largest girder had a length of 16.5 m, with a cantilever length of 7 m, and was made of glubam with a section of 800 mm deep and 120 mm wide.



(a) Mobile building for disaster relief

(b) Residential building

(c) A park house built with glubam space frames

Fig. 15 Applications

7 Conclusions

This paper introduced the current situation of glue laminated bamboo or glulam research and applications. As newly developed construction material, glulam has been proven to be applicable in buildings and bridges. The rich resources of bamboo in many parts of the world, well-established production, good mechanical properties and low impact on environment make this new material quite promising in today's trend towards a sustainable construction industry.

Acknowledgements. The research described in this paper was supported by National Natural Science Foundation of China through a National Key Project (No.50938002) and Scholarship Award for Excellent Doctoral Student granted by Ministry of Education. The writers would like to thank Advanced Bamboo and Timber Technologies (ABTT), Changsha, for their contributions in the testing and data collection.

References

- [1] Xiao, Y., Zhou, Q., Shan, B.: Design and construction of modern bamboo bridges. *ASCE Journal of Bridge Engineering* 15(Compendex), 533–541 (2010)
- [2] Xiao, Y., Shan, B., Chen, G., Zhou, Q., She, L.Y.: Development of a new type of glulam—Glulam. In: Xe, Y., et al. (eds.) *Modern Bamboo Structures*. CRC, Changsha (2008)
- [3] Laboratory, F.P.: Wood handbook—Wood as an engineering material. In: USDA FS (ed.). Madison, Wis. (1999)
- [4] Xiao, Y., Yang, R.Z., Shan, B.: Production, Environmental Impact and Mechanical Properties of Glulam. *Journal of Construction and Building Materials* (accepted, 2013)
- [5] Hammond, G., Jones, C.: Inventory of carbon & energy (ICE). Version 16a: University of Bath, UK (2008)
- [6] Buchanan, A.H., Honey, B.G.: Energy and carbon dioxide implications of building construction. *Energy and Buildings* 20(3), 205–217 (1994)
- [7] Rowlands, R.E., Rahman, M.U., Wilkinson, T.L., Chiang, Y.I.: Single- and multiple-bolted joints in orthotropic materials. *Composites* 13(3), 273–279 (1982)
- [8] Patton-Mallory, M., Pellicane, P.J., Smith, F.W.: Qualitative assessment of failure in bolted connections: Maximum stress criterion. *Journal of Testing and Evaluation* 26(Compendex), 489–496 (1998)
- [9] Echavarría, C., Salenikovich, A.: Analytical model for predicting brittle failures of bolted timber joints. *Materials and Structures* 42(7), 867–875 (2009)
- [10] ASTM. D5652 - 95(2013) Standard Test Methods for Bolted Connections in Wood and Wood-Based Products
- [11] Xiao, Y., Ma, J.: Fire simulation test and analysis of laminated bamboo frame building. *Journal of Construction and Building Materials* 34, 257–266 (2012)